

Chapter 1-3 Review Questions

1.

An astronaut on the moon throws a 5.0 kg wrench vertically upwards with an initial speed of 15 m/s. The acceleration due to gravity on the surface of the moon is one-sixth that on the surface of the earth. What is the maximum height reached by the wrench?

- A. 25 m
- B. 46 m
- C. 69 m
- D. 75 m

2.

A ball rolls off a horizontal roof at 15 m/s.

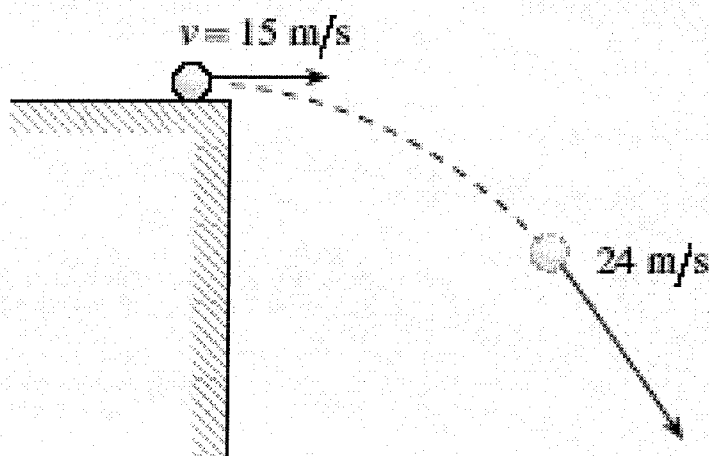

How far will the ball have fallen vertically when it reaches a speed of 24 m/s?

- A. 4.1 m
- B. 18 m
- C. 29 m
- D. 37 m

3.

A projectile is launched with a velocity of 35 m/s at 55° above the horizontal. What is the maximum height reached by the projectile? Ignore friction.

- A. 5.3 m
- B. 42 m
- C. 54 m
- D. 63 m

4.

The velocity of a moving object as observed from another moving object is called its

- A. relative velocity.
- B. associated velocity.
- C. differential velocity.
- D. comparative velocity.

5.

A green ball rolls off of the end of a table at 2.5 m/s. The table top is 1.5 m above the floor. How much time passes before the ball hits the floor?

- A. 0.35 s
- B. 0.55 s
- C. 0.60 s
- D. 1.2 s

6.

Which of the following is constant for all projectiles?

- A. vertical velocity
- B. horizontal velocity
- C. vertical displacement
- D. horizontal displacement

7.

A projectile is launched at 30 m/s over level ground at an angle of 37° to the horizontal. What maximum height does this projectile reach?

- A. 3.1 m
- B. 17 m
- C. 29 m
- D. 46 m

8.

A few minutes after takeoff a jet is heading due east with an air speed of 300 km/h. If the wind is blowing at 60 km/h, towards 40° S of E, what is the jet's ground speed?

- A. 260 km/h
- B. 340 km/h
- C. 350 km/h
- D. 360 km/h

9.

A blue ball rolls off the cliff shown below at 10 m/s and hits the ground with a speed of 30 m/s.

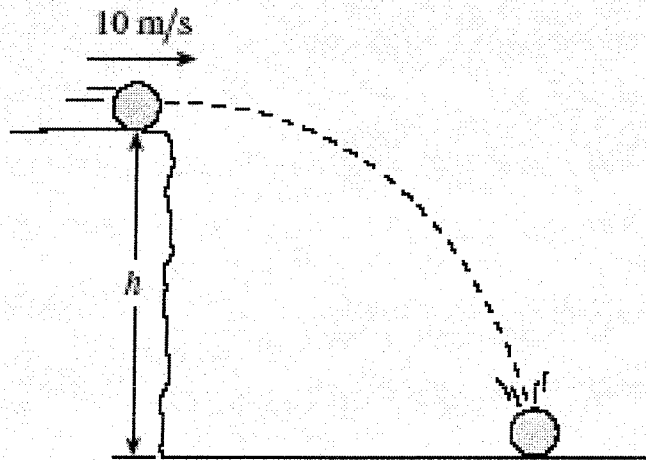

a) What is the vertical component of the ball's impact velocity?

(4 marks)

10.

Consider three points in the path of a certain projectile as shown in the diagram below.

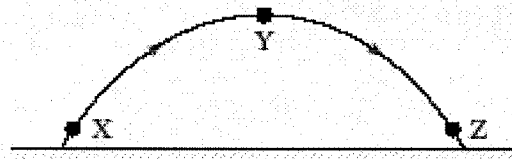

What is the acceleration of the projectile at each of these points?

ACCELERATION (m/s^2)			
	At X	At Y	At Z
A.	+9.8	0	-9.8
B.	+9.8	0	+9.8
C.	-9.8	0	-9.8
D.	-9.8	-9.8	-9.8

11.

A projectile is launched over level ground with an initial velocity of 65 m/s at 30° above the horizontal. What is the projectile's time of flight?

- A. 3.6 s
- B. 6.6 s
- C. 11 s
- D. 13 s

12.

A projectile is launched towards a wall as shown in the diagram below.

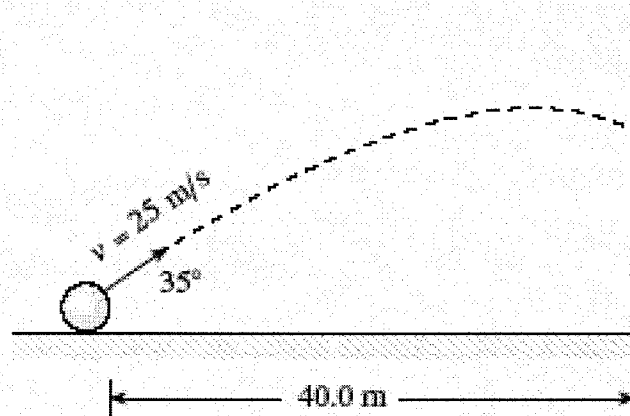

With what velocity (magnitude and direction) does the projectile hit the wall? (7 marks)

13.

Two forces act at a single point as shown.

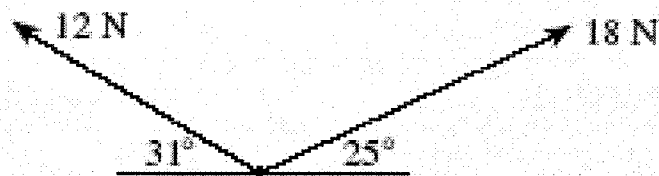

What is the magnitude of the resulting force?

- A. 15 N
- B. 22 N
- C. 27 N
- D. 30 N

14.

A 35 kg object released from rest near the surface of a planet falls 7.3 m in 1.5 s . What is the acceleration due to gravity on this planet?

- A. 4.9 m/s^2
- B. 6.5 m/s^2
- C. 9.7 m/s^2
- D. 170 m/s^2

15.

A projectile is fired into the air at some angle above the horizontal. The horizontal displacement of the projectile is measured against time in flight and the collected data is shown as a horizontal displacement versus time graph.

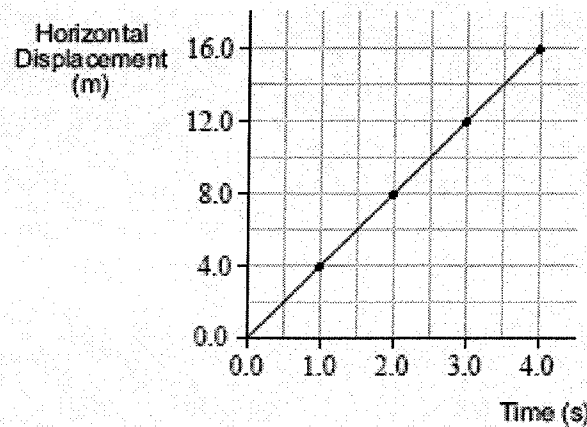

Based on this graph, the horizontal velocity of the projectile during this time interval is

- A. constant.
- B. increasing.
- C. decreasing.
- D. equal to zero.

16.

An aircraft heads due south with a speed relative to the air of 44 m/s . Its resultant speed over the ground is 47 m/s . The wind blows from the west.

a) What is the speed of the wind?

(4 marks)

b) What is the direction of the aircraft's path over the ground?

(3 marks)